

# ESE 2025

UPSC ENGINEERING SERVICES EXAMINATION

## Main Examination



# Mechanical Engineering

Topicwise *Conventional* Solved Papers

**Paper-II**

**25** Years  
SOLVED  
PAPERS

- ✓ Thoroughly revised and updated
- ✓ Fully solved with explanations
- ✓ Also useful for State Engineering Services Exams



[www.madeeasypublications.org](http://www.madeeasypublications.org)



**MADE EASY Publications Pvt. Ltd.**

Corporate Office: 44-A/4, Kalu Sarai (Near Hauz Khas Metro Station), New Delhi-110016

E-mail: [infomep@madeeasy.in](mailto:infomep@madeeasy.in)

Contact: 9021300500

Visit us at: [www.madeeasypublications.org](http://www.madeeasypublications.org)

**Mechanical Engineering**

**Topicwise Conventional Solved Papers : Paper-II : (2000-2024)**

© Copyright, by MADE EASY Publications Pvt. Ltd.

All rights are reserved. No part of this publication may be reproduced, stored in or introduced into a retrieval system, or transmitted in any form or by any means (electronic, mechanical, photo-copying, recording or otherwise), without the prior written permission of the above mentioned publisher of this book.

1st Edition : 2011

2nd Edition : 2012

3rd Edition : 2013

4th Edition : 2014

5th Edition : 2015

6th Edition : 2016

7th Edition : 2017

8th Edition : 2018

9th Edition: 2019

10th Edition: 2020

11th Edition Feb: 2022

12th Edition July: 2022

13th Edition: 2023

**14th Edition: 2024**

MADE EASY PUBLICATIONS PVT. LTD. has taken due care in collecting the data and providing the solutions, before publishing this book. In spite of this, if any inaccuracy or printing error occurs then MADE EASY PUBLICATIONS PVT. LTD. owes no responsibility. MADE EASY PUBLICATIONS PVT. LTD. will be grateful if you could point out any such error. Your suggestions will be appreciated.



## Director's Message

In past few years ESE Main exam has evolved as an examination designed to evaluate a candidate's subject knowledge. Studying engineering is one aspect but studying to crack prestigious ESE exam requires altogether different strategy, crystal clear concepts and rigorous practice of previous years' questions. ESE mains being conventional exam has subjective nature of questions, where an aspirant has to write elaborately - step by step with proper and well labeled diagrams and figures. This characteristic of the main exam gave me the aim and purpose to write this book. This book is an effort to cater all the difficulties being faced by students during their preparation right from conceptual clarity to answer writing approach.

MADE EASY Team has put sincere efforts in solving and preparing accurate and detailed explanation for all the previous years' questions in a coherent manner. Due emphasis is made to illustrate the ideal method and procedure of writing subjective answers. All the previous years' questions are segregated subject wise and further they have been categorised topic-wise for easy learning and helping aspirants to solve all previous years' questions of particular area at one place. This feature of the book will also help aspirants to develop understanding of important and frequently asked areas in the exam.

I would like to acknowledge the efforts of entire MADE EASY team who worked hard to solve previous years' questions with accuracy. I hope this book will stand upto the expectations of aspirants and my desire to serve the student community by providing best study material will get accomplished.

**B. Singh** (Ex. IES)  
CMD, MADE EASY Group

<b>1. Mechanisms and Machines..... 1-108</b>	<b>4. Manufacturing Engineering ..... 290-421</b>
1. Simple Mechanisms..... 1	1. Metal Cutting and Machine Tools ..... 290
2. Velocity and Acceleration ..... 14	2. Metal Forming..... 315
3. Kinematic and Dynamic Analysis.....23	3. Powder Metallurgy..... 340
4. Cams and Follower.....29	4. Casting ..... 344
5. Gear and Gear Trains .....34	5. Welding..... 356
6. Flywheel.....55	6. Non-Traditional Machining Methods..... 377
7. Balancing .....61	7. Metrology..... 390
8. Governors.....79	8. CAD/CAM and Automation ..... 407
9. Mechanical Vibrations.....84	
10. Gyroscope..... 100	<b>5. Industrial &amp; Maintenance Engg. .... 422-498</b>
<b>2. Strength of Materials ..... 109-211</b>	1. Break Even Analysis ..... 422
1. Simple Stress-strain and Elastic Constant .... 109	2. Inventory Control ..... 426
2. Strain Energy and Thermal Stresses ..... 118	3. Forecasting..... 441
3. Shear Force & Bending Moment Diagram .... 124	4. PERT/CPM ..... 452
4. Bending Stress & Shear Stress in Beams ..... 135	5. Linear Programming..... 461
5. Torsion of Shafts ..... 148	6. Assignment and Transportation..... 468
6. Principal Stress-strain & Theories of Failure..... 156	7. Queuing Theory ..... 478
7. Deflection of Beams ..... 169	8. Sequencing ..... 480
8. Pressure Vessels ..... 180	9. Production Planning and Control ..... 485
9. Theory of Columns..... 186	10. Line Balancing..... 488
10. Engineering Mechanics ..... 188	11. Maintenance Engg. + Miscellaneous ..... 489
<b>3. Design of Machine Elements ..... 212-289</b>	<b>6. Engineering Materials ..... 499-535</b>
1. Design for Static and Dynamic Loading ..... 212	1. Crystal System ..... 499
2. Bearing ..... 213	2. Phase Diagrams ..... 505
3. Clutches and Brakes ..... 224	3. Heat Treatment ..... 510
4. Gear ..... 233	4. Properties and Application of Ferrous and Non-Ferrous Material and Corrosion ..... 517
5. Bolted, Welded and Riveted Joint..... 242	5. Plastic, Ceramic, Composite and Nano-Materials..... 527
6. Joint, Shaft, Key and Coupling..... 254	
7. Belt, Rope and Chain Drive ..... 273	<b>7. Mechatronics and Robotics ..... 536-595</b>
8. Power Screw ..... 279	
9. Spring ..... 284	
10. Flywheel..... 288	



# 1

# Mechanisms and Machines

**Revised Syllabus of ESE :** Types of Kinematics Pair, Mobility, Inversions, Kinematic Analysis, Velocity and Acceleration Analysis of Planar Mechanisms, CAMs with uniform acceleration and retardation, cycloidal motion, oscillating followers; Vibrations –Free and forced vibration of undamped and damped SDOF systems, Transmissibility Ratio, Vibration Isolation, Critical Speed of Shafts. Gears – Geometry of tooth profiles, Law of gearing, Involute profile, Interference, Helical, Spiral and Worm Gears, Gear Trains- Simple, compound and Epicyclic; Dynamic Analysis – Slider – crank mechanisms, turning moment computations, balancing of Revolving & Reciprocating masses, Gyroscopes – Effect of Gyroscopic couple on automobiles, ships and aircrafts, Governors.

## 1. Simple Mechanisms

**1.1** The dimensions of different links of the crank and slotted lever quick-return mechanism shown in figure are given below:

$$O_1O_2 = 700 \text{ mm}, O_1B = 250 \text{ mm}$$

$$O_2D = 1250 \text{ m}, DR = 350 \text{ mm}$$

The crank  $O_1B$  rotates at 40 r.p.m. in the counter clockwise direction and at the present instant of consideration makes an angle of  $45^\circ$  with the vertical.

Determine:

1. Velocity of the ram  $R$  which moves in a horizontal direction.
2. Angular velocity of link  $O_2D$ .

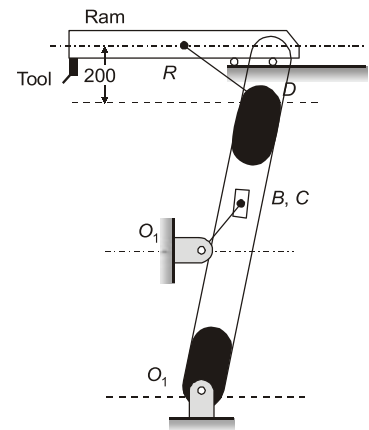

[20 marks : 2006]

**Solution:**

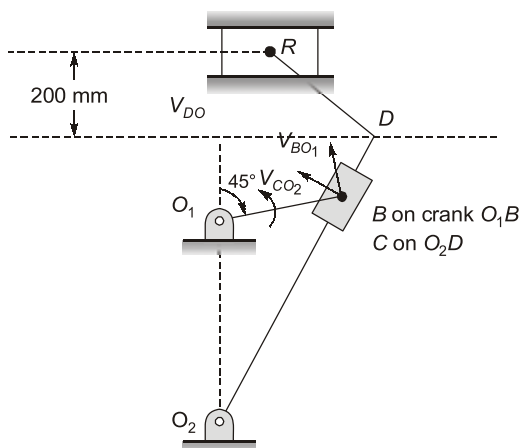

Space diagram

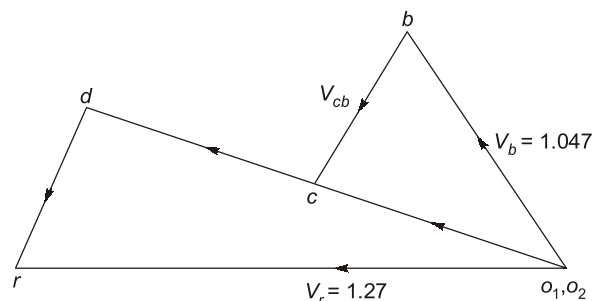

Velocity diagram

$$\begin{aligned} \text{Scale } 150 \text{ mm} &= 1 \text{ cm}, & O_1O_2 &= 700 \text{ mm} = 4.67 \text{ cm} \\ & & O_1B &= 1.67 \text{ cm} \\ & & O_2D &= 8.33 \text{ cm} \\ & & DR &= 2.33 \text{ mm} \end{aligned}$$

First of all draw the space diagram or configuration diagram. By assuming suitable scale.

Since  $o_1$  and  $o_2$  are fixed points therefore these points are marked as one point in velocity diagram, draw vector  $o_1b$  perpendicular to  $O_1B$  such that

$$o_1b = V_B = \left( \frac{2\pi N}{60} \right) \times O_1B = \left( \frac{2\pi \times 40}{60} \right) \times 0.25 = 1.047 \text{ m/s}$$

$$\text{Scale } 0.5 \text{ m/s} = 1 \text{ cm},$$

$$O_1b = 1.047 \text{ m/s} = 2.09 \text{ cm} \approx 2.1 \text{ cm}$$

$$\frac{O_2D}{O_2C} = \frac{8.33 \text{ cm}}{5.83 \text{ cm}} = \frac{o_2d}{o_2c} = \frac{o_2d}{1.7 \text{ cm}}$$

$$o_2d = 2.428 \text{ cm}$$

$$o_2c = 1.7 \text{ cm}$$

$$o_2R = 2.54 \text{ cm}$$

$$\text{Velocity of point, } d = 2.428 \times 0.5 = 1.2144 \text{ m/s}$$

$$\omega_{O_2D} \times O_2D = 1.2144$$

$$\omega_{O_2D} = \frac{1.2144}{1.250} = 0.971 \text{ rad/s}$$

$$\text{Velocity of ram} = 2.54 \times 0.5 = 1.27 \text{ m/s}$$

- 1.2** Determine the maximum and minimum transmission angle of the mechanism shown which is driven by member  $O_1A$ .

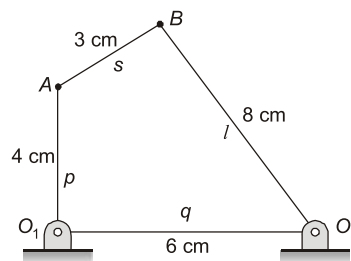

[2 marks : 2012]

**Solution:**

According to the Grashof law:

$$(l + s) < (p + q)$$

$$(8 + 3) < (4 + 6) \Rightarrow \text{Not satisfied}$$

and hence mechanism type is class-II rocker-rocker mechanism.

- 1.3** One of the turning pairs of a four bar chain is replaced by a sliding pair. Draw the inversions by fixing different links. Give one application for each of the mechanism.

[10 marks : 2013]

**Solution:**

First-inversion

**Practical application.**

Example: reciprocating engine diagram.

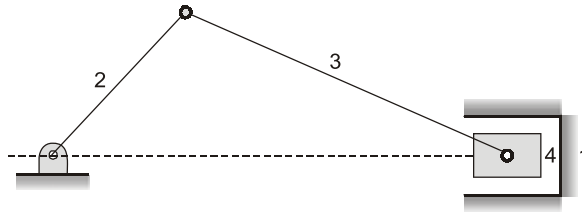

Second-inversion

**Practical application.**

Example: Whitworth quick return mechanism

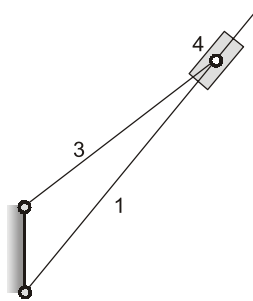

Third-inversion

**Practical application.**

Example: Oscillating cylinder engine

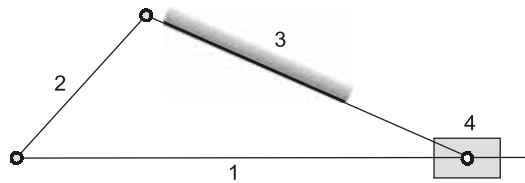

Fourth-inversion

**Practical application.**

Example: Hand pump

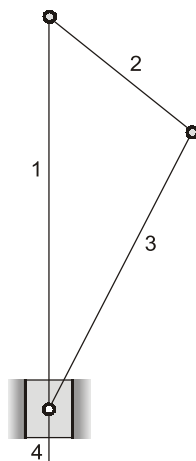

**1.4** Draw a crank rocker mechanism and identify all instantaneous centers.

[4 marks : 2014]

**Solution:**

Crank rocker mechanism.

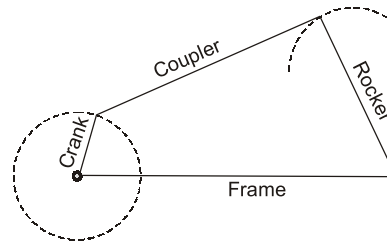

Crank Rocker Mechanism

Identified instantaneous centres.

Total number of link,  $n = 4$

$$\text{Number of } I \text{ centres} = \frac{n(n-1)}{2} = 6$$

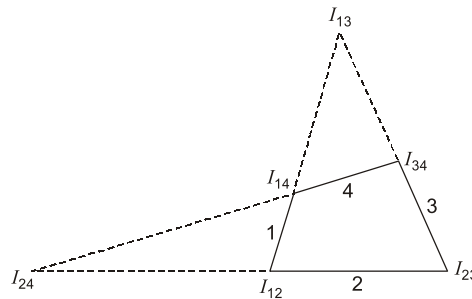
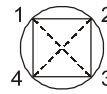

Identification of Instantaneous Centres

**1.5** Explain Grashof's linkage. Explain the inversions of this linkage.

[4 marks : 2015]

**Solution:**

**Grashof's Law** : For continuous relative motion between number of link in a four bar mechanism the summation of length of the shortest and longest link should not be greater than the other two links.

If Grashof's law is not satisfied, motion will be discontinuous.

**Inversions of linkage:**

$s, p, q, l$  are the lengths of 4 links, where  $s$  is shortest and  $l$  is longest link and Grashof law is satisfied.

(i) when all links of unequal size.

$$s \neq p \neq q \neq l$$

if  $s$  – fixed  $\rightarrow$  double crank mechanism.

if  $s$  – adjacent to fixed  $\rightarrow$  crank rocker mechanism.

if  $s$  – coupler  $\rightarrow$  double crank mechanism

(ii) When same sizes

(a) Placed opposite to each others

$$\begin{aligned} s &= p \\ l &= q \end{aligned}$$

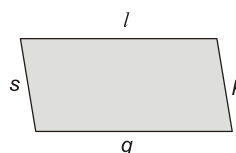

When pair of links having equal size if fixed any one of them always get double crank which is known by Parallelogram linkage.



(b) When same size links adjacent to each other and it is known by deltoid linkage.

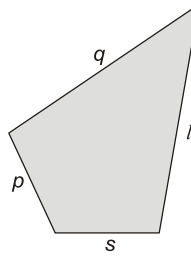

if  $s$  – fixed  $\rightarrow$  double crank mechanism.

if  $l$  – fixed  $\rightarrow$  crank and rocker mechanism.

**1.6** The crank of a crank and slotted lever quick return mechanism is driven at 120 rpm clockwise. The vertical distance between the centres of rotation of the crank and slotted lever is 50 cm. What should be the length of the crank if the quick return ratio is 1 : 2? Determine the angular velocity of the slotted lever, when the tool-post attains maximum velocity during cutting stroke.

[4 marks : 2016]

**Solution:**

$$N_{\text{crank}} = 120 \text{ rpm (clockwise)}$$

$$\omega_{\text{crank}} = \frac{2\pi \times 120}{60} = 4\pi \text{ rad/s}$$

$$\text{Quick return ratio} > \frac{\alpha}{\beta} = \frac{1}{2}$$

$\Rightarrow$

$$\frac{\beta}{\alpha} = \frac{2}{1}$$

$$360 - \alpha = 2\alpha$$

$$3\alpha = 360^\circ$$

$$\alpha = 120^\circ$$

$$OA = 50 \text{ cm}$$

$$\cos \frac{\alpha}{2} = \frac{OB}{OA} = \frac{OB}{50}$$

$$\cos 60^\circ = \frac{OB}{50}$$

$$\frac{1}{2} = \frac{OB}{50}$$

$\Rightarrow$

$$OB = 25 \text{ cm}$$

$$\text{Length of crank} = 25 \text{ cm}$$

$$\text{Velocity of slider, } V_B = r_{\text{crank}} \times \omega_{\text{crank}} = 0.25 \times 4\pi = \pi \text{ m/s}$$

Maximum velocity of slotted bar in cutting stroke (Mid position)

For maximum velocity position

$$AC = \frac{50 + 25}{100} = 75 \text{ cm} = 0.75 \text{ m}$$

$$V_C = AC \times \omega_{\text{slotted lever}}$$

$$V_C = V_B = \pi \text{ m/s} = 0.75 \times \omega_{\text{slotted lever}}$$

$$\omega_{\text{slotted bar}} = 4.188 \text{ rad/s}$$

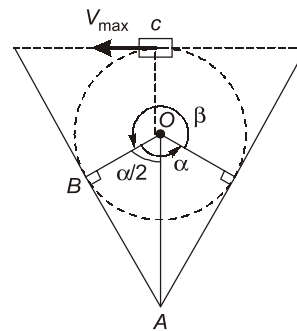

- 1.7** (i) Distinguish and differentiate between machine and mechanism. Define the term inversion of a kinematic chain.
- (ii) Discuss about the possible inversions (with figures) of a four bar chain.

[12 marks : 2018]

**Solution:**

- (i) **Machine and Mechanism:** If a number of bodies are assembled in such a way that the motion of one causes constrained and predictable motion to the others, it is known as a mechanism. A mechanism is a fundamental unit. A mechanism transmits and modifies a motion.

A machine is mechanism or a combination of mechanism which, apart from imparting definite motions to the parts, also transmits and modifies the available mechanical energy into some kind of desired work.

**Inversion of a kinematic chain:** Different mechanisms obtained by fixing different links of a kinematic chain are known as its inversion.

If number of links in a kinematic chain =  $l$

$$\text{Number of inversions} \leq l$$

- (ii) **Inversions of a four bar chain:**

If Length of shortest link =  $s$

Length of longest link =  $l$

Length of remaining two link =  $p$  and  $q$

By Grashof's law,

For continuous relative motion,

$$s + l \leq p + q$$

**Case-I:**

If  $s + l < (p + q)$

1. If shortest link is fixed  $\rightarrow$  We obtain double crank mechanism.
2. If shortest link is adjacent to fixed  $\rightarrow$  We obtain crank rocker mechanism.
3. If shortest link is opposite to fixed link  $\rightarrow$  We obtain class -I double rocker mechanism.

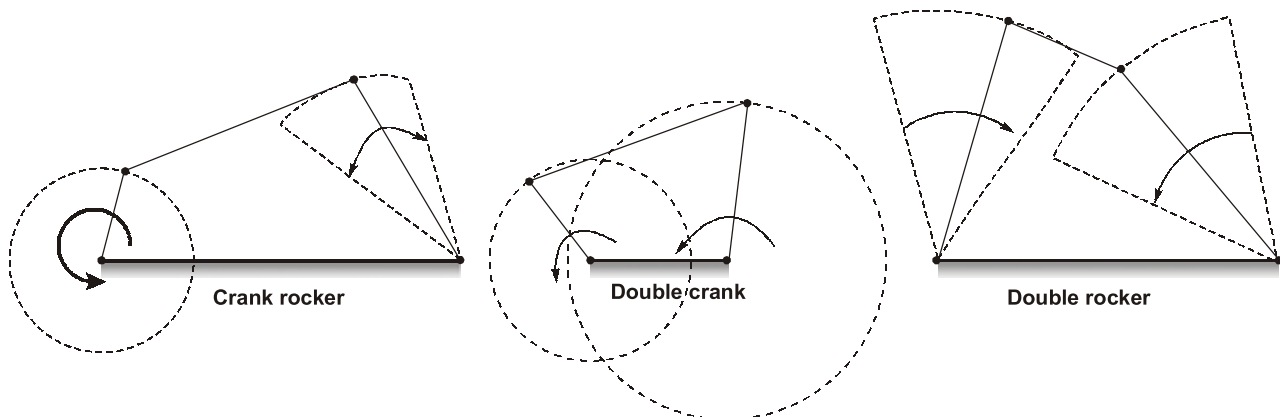
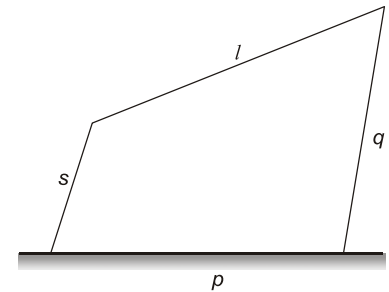
**Case-II:**

If  $s + l = (p + q)$

1. If link are not having equal length but law,  $(s + l = p + q)$  is satisfied. Then the conditions mentioned in case I will be applied in this case also.
2. If links are having equal lengths:

- A. If equal length links are parallel to each other → By fixing either shortest link or longest we are going to obtain double crank mechanism. It is known as golden chain or parallelogram linkage.

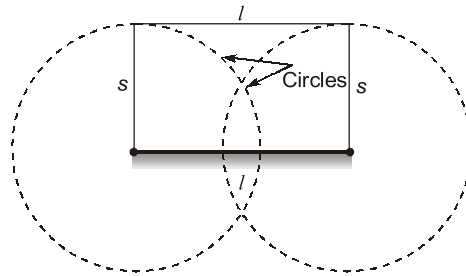

- B. If equal length links are adjacent to each other.
- If we fix shortest link → we obtain double crank mechanism.
  - If we fix longest link → we obtain crank roker mechanism

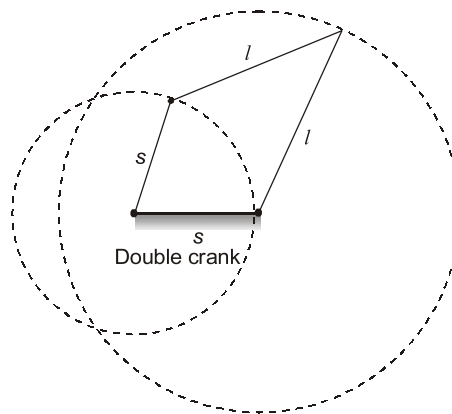

### Case-III:

If  $s + l > (p + q)$

In this case by fixing any link we are going to have class -II double rocker mechanism.

### 1.8 What is kinematic pair? How are kinematic pairs classified? Explain.

[6 marks : 2019]

#### Solution:

Kinematic pair: The connection between the two link is a joint or pair and this pair will be a kinematic pair if the relative motion between the links is a constrained motion (completely constrained motion or successfully constrained motion)

**Kinematic pair can be classified according to**

- Nature of contact
- Nature of mechanical constraint
- Nature of relative motion

#### 1. According to the nature of contact.

- Lower pair : When pair/joint having surface or area contact between the members.  
Example: Nut turning on a screw, shaft rotation in a bearing, all pairs of slider crank mechanism and universal joint.
- Higher pair: When pair/joint having line or point contact between members.  
Example: Wheel rolling on a surface, cam and follower pair, ball and roller bearings.
- Wrapping pair: When one link is wrapped over other link.  
Example: Belt and pulley, rope and pulley.

**2. According to the nature of mechanical constraint.**

- (a) Closed pair/self closed pair: When the elements of pair are held mechanically. Generally all the lower pair and some of the higher pair are closed pairs.
- (b) Force closed pair/ unclosed pair/forcefully closed pair: When the elements of a pair form contact either due to force of gravity or by some spring action, then it is known as force closed pair.  
Example: cam and follower pair.

**3. According to the nature of relative motion:**

- (a) Sliding pair: If the two links having a translatory/sliding motion to each other.  
Example: A rectangular rod in a rectangular hole in a prism is a sliding pair.
- (b) Turning pair: If the two links having rotary/turning motion relative to each other then they form turning pair.  
Example: Circular shaft inside a bearing forms turning pair pin joint.
- (c) Rolling pair: When the links of pair have pure rolling motion.  
Example: A rolling wheel on a flat surface in a ball bearing, the ball and the shaft constitute one rolling pair.
- (d) Screw pair (helical pair): When links of pair having a turning as well as sliding motion between them.  
Example: Lead screw and the nut of a lathe form screw pair.
- (e) Spherical pair: When one link in the form of sphere turns inside a fixed link then it forms spherical pair.  
Example: The ball inside the socket forms spherical pair.

- 1.9** (i) Explain about a double slider crank chain and its inversions.  
(ii) The distance between two parallel shafts is 18 mm and they are connected by an Oldham's coupling. The driving shaft revolves at 160 rpm. What will be the maximum speed of sliding of the tongue of the intermediate piece along the groove?

[12 marks : 2020]

**Solution:**

(i)

**Double Slider-Crank Chain**

A kinematic chain consisting of two turning pairs and two sliding pairs is called double slider-crank chain as shown.

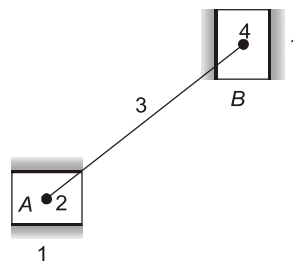

Double Slider-Crank chain

**Inversions of Double slider crank chain**

1. **First Inversion (Elliptical Trammel)** : It is a device to draw ellipses in which two grooves are cut at right angles in a plate that is fixed. The plate forms the fixed link 1. Two sliding blocks are fitted into the grooves. The slides form two sliding links 2 and 4. The link joining slides form the link 3. Any point on link 3 or on its extension traces out an ellipse on the fixed plate, when relative motion occurs.

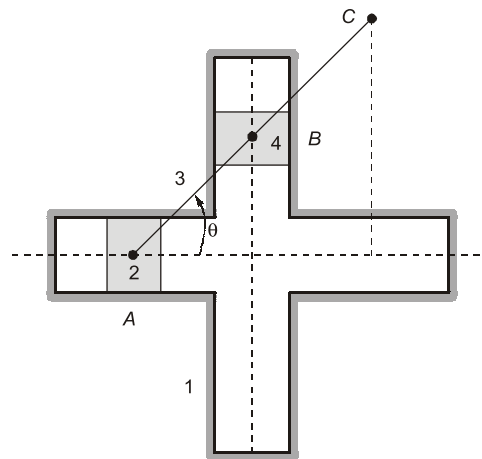

Elliptical Trammel

2. **Second Inversion (Scotch Yoke)** : If any of the slide-blocks of the first inversion is fixed, the second inversion of the double-slider-crank chain is obtained as shown in figure. This mechanism gives SHM. Its early application was on steam pumps, but it is now used as a mechanism on a test machine to produce vibrations. It is also used as a sine-cosine generator for computing elements.

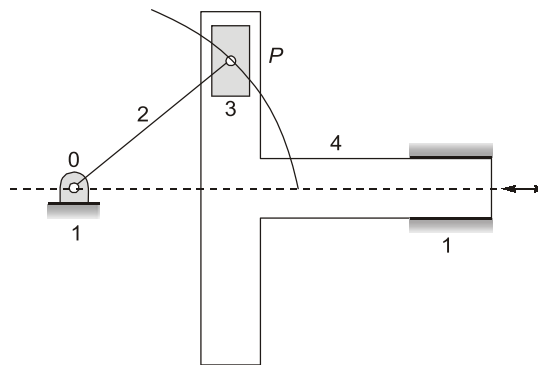

Scotch Yoke

2. **Third Inversion (Oldham's coupling)** : The Oldham's coupling is used to connect two parallel shafts, the distance between whose axes is small and variable. The shafts have flanges at the ends, in which slots are cut. These form links 2 and 4. An intermediate piece circular in shape and having tongues at right angles on opposite sides, is fitted between the flanges of the two shafts in such a way that the tongues of the intermediate piece get fitted in the slots of the flanges. The intermediate piece forms link 3, which slides or reciprocates in links 2 and 4. The link 1 is fixed.

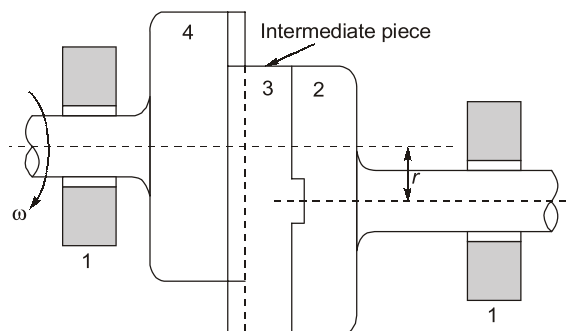

Oldham's coupling

Maximum sliding speed of each tongue along at slot = (Distance between the shafts)  
× (Angular velocity of shaft)

(ii)

$$r = 18 \text{ mm} = 0.018 \text{ m,}$$

$$N_{\text{driver}} = 160 \text{ rpm}$$

$$\omega_{\text{driver}} = 2\pi \times \frac{160}{60} = 16.7551 \text{ rad/s}$$

$$\begin{aligned} \text{Maximum velocity of sliding} &= r\omega_{\text{driver}} \\ &= 0.018 \times 16.751 \\ &= 0.30159 \text{ m/s} \end{aligned}$$

Ans.

**1.10** Define kinematic chain. Find all the inversions of the chain shown in the figure.

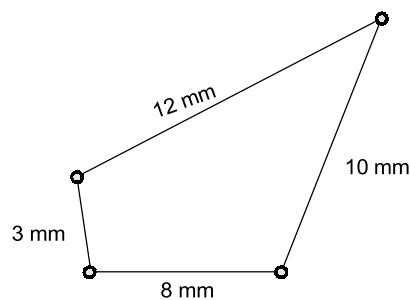

[12 marks : 2022]

**Solution:**

Shortest link length,  $s = 3 \text{ mm}$   
Longest link length,  $l = 12 \text{ mm}$   
Other two link length,  $p = 10 \text{ mm}$  and  $q = 8 \text{ mm}$

$$(s + l) = 3 + 12 = 15 \text{ mm}$$

$$(p + q) = 10 + 8 = 18 \text{ mm}$$

Here,  $(s + l) < (p + q)$

Since the sum of the lengths of the shortest and longest link is lesser than the sum of the lengths of the other two links, Grashoff's law is satisfied for the inversion.

Inversions of the given chain are given below:

1. Double crank mechanism : It is obtained when the link of length 3 mm is fixed.
2. Crank-rocker mechanism : It can be obtained when the 8 mm link is fixed with 3 mm link adjacent to it or when 12 mm link is fixed with 3 mm link adjacent to fixed.
3. Double rocker mechanism : It is obtained when 10 mm link is fixed and 3 mm link is the coupler.

**1.11** Describe all the inversions of a slider-crank mechanism.

[12 marks : 2023]

**Solution:**

Taking a different link as the fixed link, the slider-crank mechanism shown in figure (a) can be inverted into the mechanisms shown in figure (b), (c) and (d).

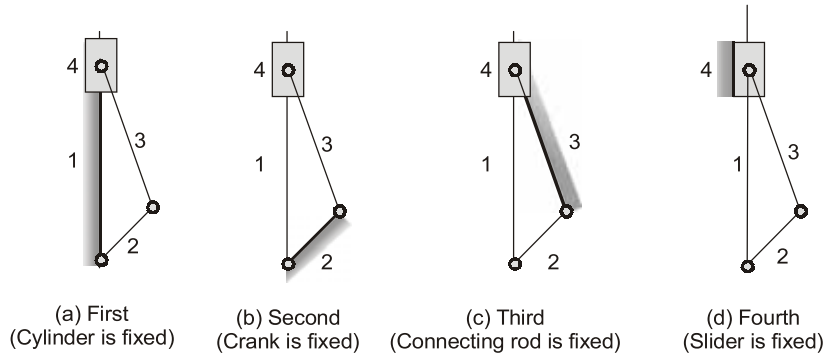

**First inversion [fig. (a)]**

This inversion is obtained when link 1 (i.e.; cylinder) is fixed.

**Applications:**

- Reciprocating engine
- Reciprocating compressor

**Second inversion [fig. (b)]**

Fixing of the link 2 (i.e. crank) of a slider-crank chain results in the second inversion.

**Applications:**

- Whitworth quick return mechanism
- Rotary engine (GNOME engine)

**Third inversion [fig. (c)]**

By fixing of the link 3 (i.e. connecting rod) of the slider-crank mechanism, the third inversion is obtained.

**Applications:**

- Oscillating cylinder engine
- Crank and slotted-lever mechanism

**Fourth inversion [fig. (d)]**

If the link 4 (i.e. slider) of the slider-crank mechanism is fixed, the fourth inversion is obtained.

**Applications:**

- Hand pump

Summary of slider Crank Chain and its Inversions				
Mechanism	Links			
	Fixed	Rotates	Oscillates	Reciprocates
Single slider crank chain	1	2	3	4
<b>INVERSIONS:</b>				
Pendulum pump	4	2	3	1
Oscillating cylinder engine	3	2	4	1
Crank-slotted lever	3	2	4	1
Whitworth mechanism	2	3	1	4
Gnome engine	2	3	1	4